

# Nanjing Qiming Machinery Co.,Ltd

## QM-442.8421 Size Report

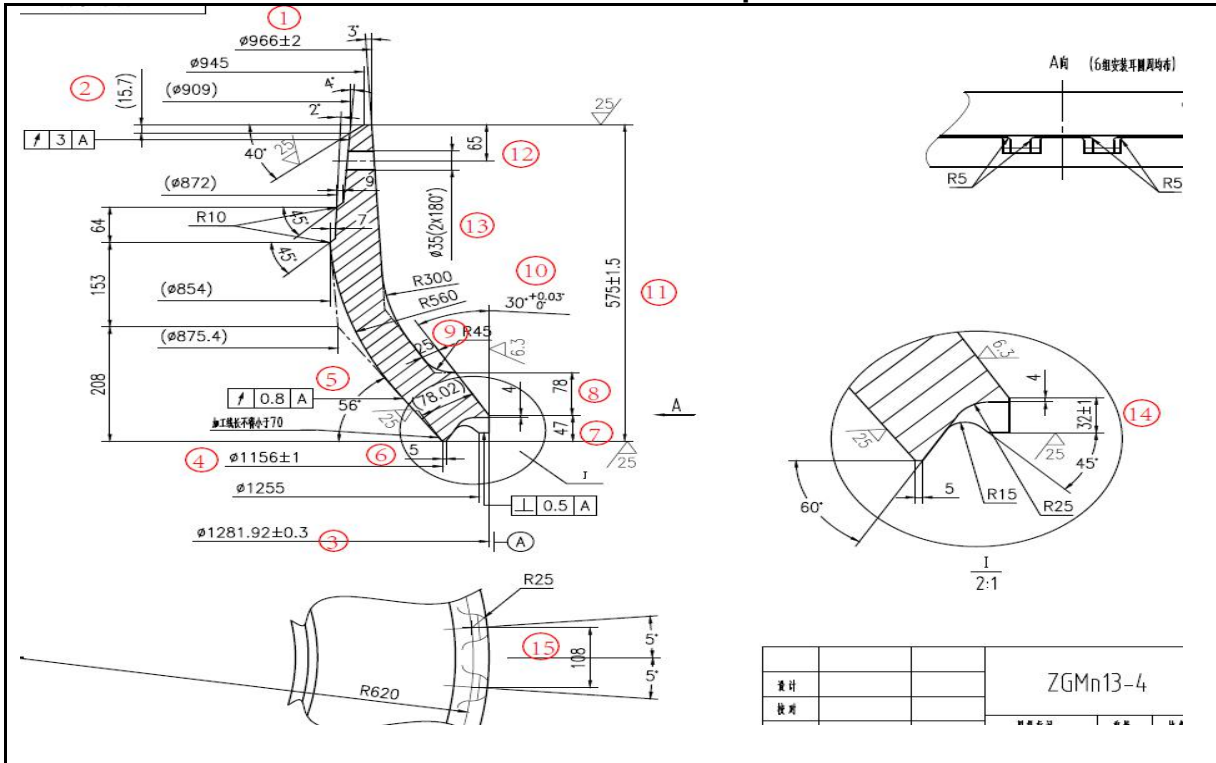

				ZGMn13-4
设计				
校核				

Part name	Cone Liner	Part No	442.8421	Order number	51E0807	Check Date	2019.5.29	QA
Location	Drawing	Tolerance	Measured value	Qualified decision	recheck	WT		845Kg
1	966	$\pm 2$	$\phi 968$					
2	15.7		15-16					
3	1281.92	$\pm 0.3$	$\phi 1281.7$					
4	1156	$\pm 1$	$\phi 1155$					
5	56°		55.8°					
6	5		5					
7	47		48					
8	78		76					
9	25		24-25					
10	30°	$+0.03^\circ$ $0^\circ$	30°4'					
11	575	$\pm 1.5$	575.5					
12	65		66-67					
13	35		$\phi 38$					
14	32	$\pm 1$	33					
15	108		108					
16								
17								
18								
19								
20								

NOTE: Dimensions with mark "x" are out of tolerance.