

Nanjing Qiming Machinery Co.,Ltd

QM-442.7225 Size Report

Item: QM-JZB-J015A

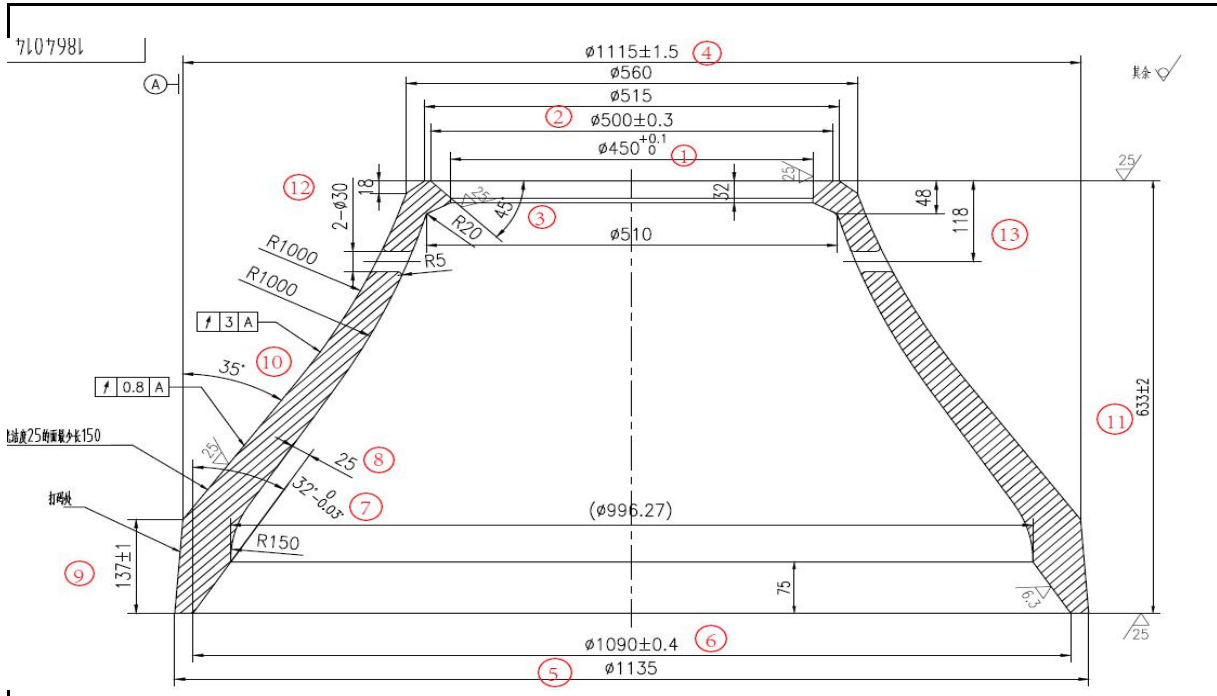

Part name	Cone Crusher Liner	Part No	442.7225	Order number	4IE0901	Check Date	2019.6.4	QA
Location	Drawing	Tolerance	Measured value	Qualified decision	Recheck	WT		674Kg
1	φ450	+0.1 0	φ450					
2	φ500	±0.3	φ500					
3	45°		45.5°					
4	φ1115	±1.5	φ1114					
5	φ1135		φ1130					
6	φ1090	±0.4	φ1089.6					
7	32°	0° -0.02°	31°56'					
8	25		23-24					
9	137	±1	138-139					
10	35°		35.2°					
11	633	±2	634					
12	30		φ32					
13	118		118					
14								
15								
16								
17								
18								

NOTE: Dimensions with mark "x" are out of tolerance.